

Scrubber 50



Scrubber 50



Scrubber 50 Workstation

Key Benefits

Cleans Productively

Coverage of up to 17,800 sqft/hr and unparalleled ability to clean small areas

Saves Energy

Calculates the most efficient path using advanced AI navigation systems to reduce wasted energy

Ease of Use

Minimizes human assistance with sophisticated yet simple software

Low Maintenance

Requires only two (2) hours of general monthly maintenance

People-Friendly

Releases custodians from tedious, repetitive, and injury-inducing work

Core Features

Advanced AI Navigation

- Runs the most efficient cleaning coverage
- Cleans large areas without losing its location

Powerful Vacuum and Brushes

- Removes dirt, grease, and scuff marks quickly
- Leaves no trace of water behind

State-of-the-Art Safety Features

- World-class sensors and sensor fusion algorithms
- Instant detection of moving and stationary obstacles

Real-time Reports

- Machine performance reports, accessible from anywhere
- Updates with detailed cleaning status at any time

Automatic Workstation

- Empties dirty water, refills with clean water, and charges automatically
- Resumes unfinished tasks when finished charging

Beyond Expectations

- Saves up to 70% of fresh water
- Recycles dirty water using unique 4-stage-filtration system

Specifications

Dimensions	34 in x 28 in x 41 in
Unladen Weight	331 lb
Cleaning Width	20 in
Max. Cleaning Productivity	12,000 sqft/hr
Rated Voltage	24V
Max. Output Power	1200W
Max. Air Flow Volume	70 cu ft
Max. Climbing Degree	4.6°
Travel Speed	0-2.3 mph
Rotating Disc/Brush	9 in
Dust Mop	Compatible
Clean/Recovered Water Tank	6 gal / 5 gal
Max. Battery Time	3 hrs

Sensor Systems

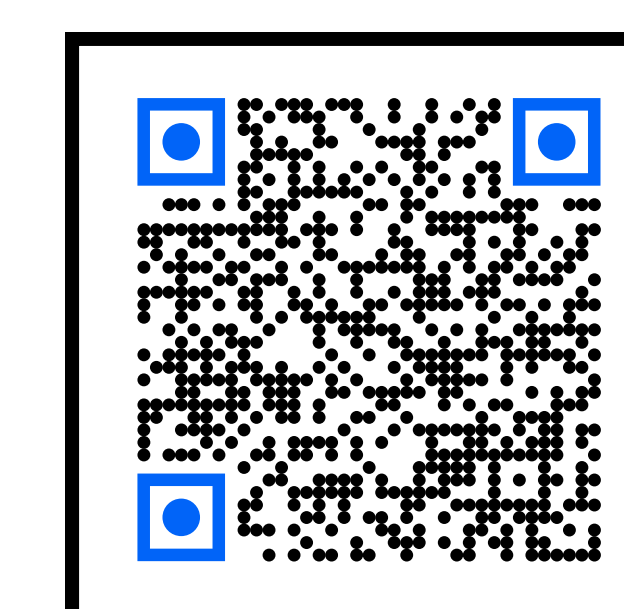
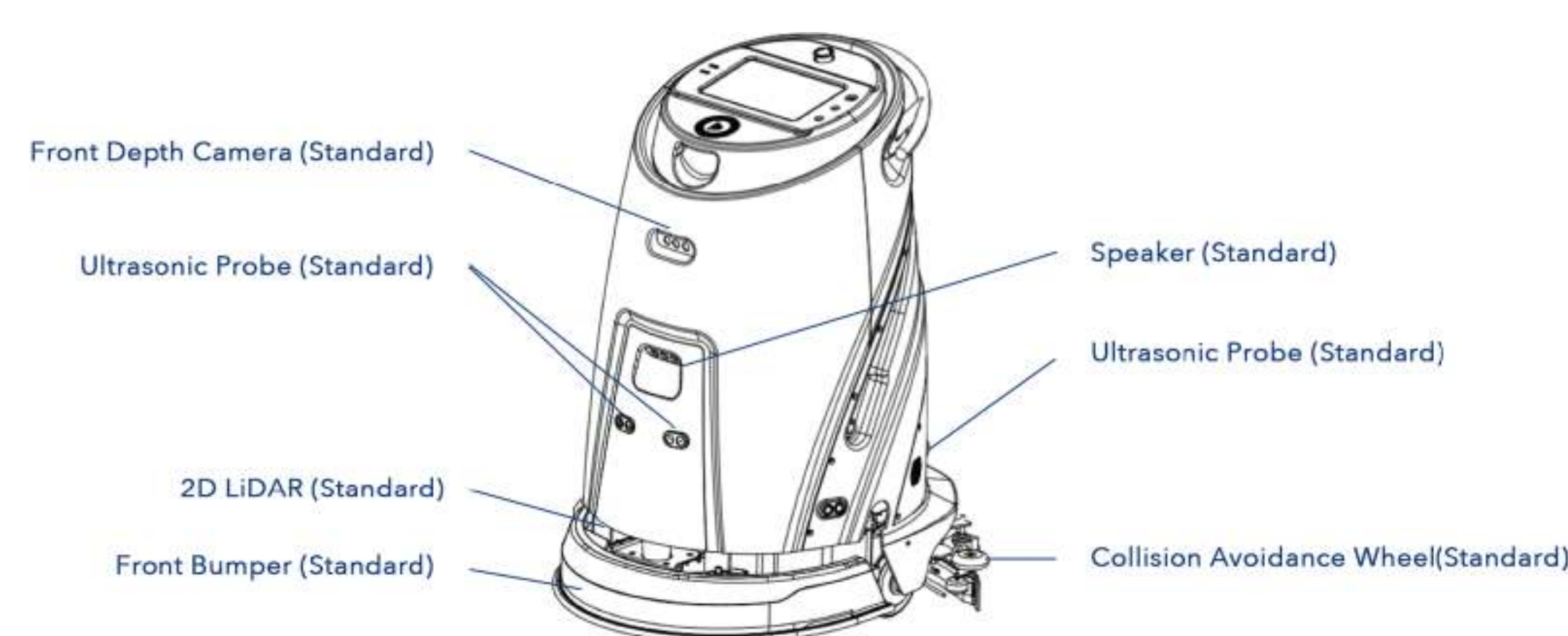

Applicable Scenarios



Education



Hospitality



Hospitals



Warehouse



Stores

Labor Cost Comparison

Mop and Bucket

\$ 1.10

cents / sq ft

IMOP

\$ 0.40

cents / sq ft

Scrubber 50

\$ 0.00

cents / sq ft

Ride-on Vacuum

\$ 0.14

cents / sq ft

Flooring Types



Stone



Vinyl



Ceramic



Concrete



Epoxy